

FILTER PRESSURE REGULATORS

DESCRIPTION	PRESSURE RANGE bar	CONNECTION thread	SERIES	PAGE
„Miniature“-Series	0.2 ... 1,8 / 9	G $\frac{1}{8}$ and G $\frac{1}{4}$	B548	17.02
„Midi“-Series made of metal	0.2 ... 1,8 / 17	G $\frac{1}{4}$ - G $\frac{1}{2}$	B11, B12	17.03
made of plastic	0 ... 4 / 12	G $\frac{1}{4}$ - G1	B042 ... B095	17.04
„Maxi“-Series, robust, modular	0.2 ... 4 / 17	G $\frac{1}{4}$ - G1	B20, B21	17.05
Series „D“, made of aluminium / die-cast zinc	0.3 ... 3 / 15	G $\frac{1}{8}$ - G2	BD	17.06
down to -40 °C / -40 °F	0 ... 0.7 / 8	$\frac{1}{4}$ " NPT	B300	17.08



17

Description	Regulator of small and compact design, ideal for limited space conditions.		
Media	compressed air or non-corrosive gases		
Supply pressure	max. 11 bar for plastic bowl, max. 21 bar for metal bowl		
Adjustment	by plastic knob with snap-lock		
Relieving function	relieving		
Gauge port	G $\frac{1}{8}$ on both sides of the body, screw plugs supplied		
Filter element	20 μ m, optionally 5 μ m, made of polypropylene		
Bowl	plastic or metal version		
Drainage	manual drain as standard, for max. 21 bar semiautomatic drain as option, for max. 12 bar		
Temperature range	0 °C to 50 °C / 32 °F to 122 °F for plastic bowl and semiautomatic drain version 0 °C to 80 °C / 32 °F to 176 °F for metal bowl		
Material	Body: aluminium	Elastomer: NBR/Buna-N	Inner valve: brass
	Spring cage: glass fibre-reinforced plastic		
	Bowl: polyurethane or zinc die-cast		

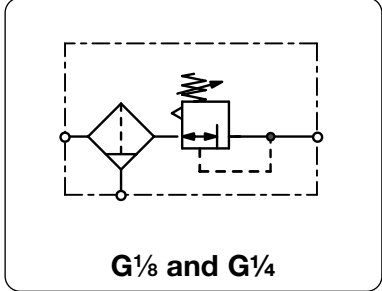

Dimensions			Bowl	Flow	P ₁	Connection	Pressure	Order
A	B	C	design	rate	max.	thread	range	number
mm	mm	mm	made of	l m ³ /h*1	l/min*1	G	bar	

Miniature filter regulator			with manual drain, relieving, without gauge, filter element 20 μ m					B548		
40	152	86	plastic	0.04	27	450	11	G $\frac{1}{8}$	0.2...1.8	B548-01AHA
									0.2...4.0	B548-01AHB
									0.3...9.0	B548-01AHC
		metal	21	0.2...1.8	B548-01DHA					
				0.2...4.0	B548-01DHB					
				0.3...9.0	B548-01DHC					
40	152	86	plastic	0.04	27	450	11	G $\frac{1}{4}$	0.2...1.8	B548-02AHA
									0.2...4.0	B548-02AHB
									0.3...9.0	B548-02AHC
		metal	21	0.2...1.8	B548-02DHA					
				0.2...4.0	B548-02DHB					
				0.3...9.0	B548-02DHC					



Special options, add the appropriate letter

5 μ m filter element	B548-0..G.
NPT connection thread	B548-0...N
non-relieving function	B548-0...K
semiautomatic drain RK500SY, max. 12 bar	B548-0...M

Accessories, enclosed

pressure gauge	Ø 40 mm, 0...*2 bar, G $\frac{1}{8}$	MA4001-...*2
mounting bracket	made of steel	BW30-02
mounting nut	made of plastic	M30x1,5K
	made of aluminium	M30x1,5A

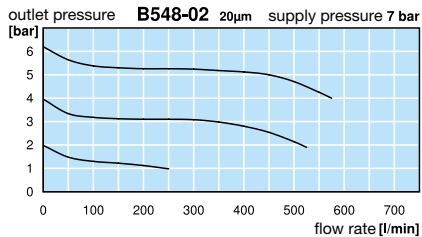
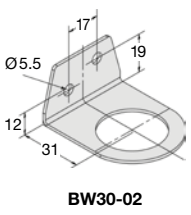
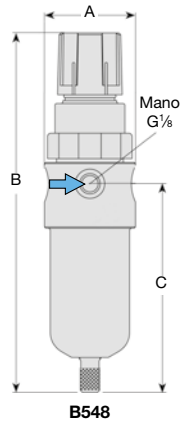

*1 at 7 bar supply pressure, 6 bar outlet pressure and 1 bar pressure drop
*2 02 = 0...2.5 bar, 04 = 0...4 bar, 10 = 0...10 bar

Extensions: see chapter for FRL service units
Gauges: see chapter for measuring devices
Spare parts: see separate spare parts list

PDF CAD
www.aircom.net

Order example:
B548-01AHA

Filter regulator
17

"MIDI" FILTER PRESSURE REGULATOR

B11 / B12

Description	Filter pressure regulator with high flow and of small design.		
Media	compressed air or non-corrosive gases		
Supply pressure	max. 17 bar for metal bowl with sight glass, max. 21 bar for metal bowl without sight glass		
Adjustment	by plastic knob with snap-lock at B11, by T-handle with locknut at B12		
Relieving function	relieving	Gauge port	G $\frac{1}{4}$ on both sides of the body, screw plugs supplied
Filter element	40 μ m, optionally 5 μ m, made of polypropylene		
Bowl	metal version with sight glass, optionally without		
Drain	manual drain as standard, for max. 21 bar, semiautomatic or automatic drain as option, for max. 12 bar		
Temperature range	0 °C to 70 °C / 32 °F to 158 °F for metal bowl with sight glass 0 °C to 80 °C / 32 °F to 176 °F for metal bowl without sight glass 0 °C to 50 °C / 32 °F to 122 °F for semiautomatic or automatic drain for appropriately conditioned compressed air down to -30 °C / -22 °F at B12		
Material	Body: zinc die-cast	Bowl: zinc die-cast	
	Inner valve: brass, optionally stainless steel	Elastomer: NBR/Buna-N, optionally FKM	
	Spring cage: glass fibre-reinforced plastic at B11, zinc die-cast at B12		

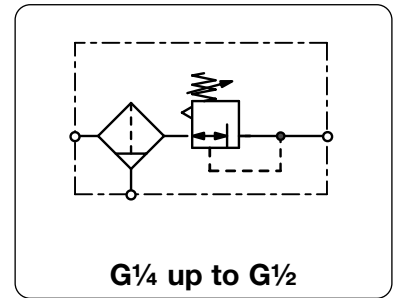

Dimensions			Bowl	Flow	Supply	Connection	Pressure	Order
A	B	C	Design	Capacity	rate	max.	thread	range
mm	mm	mm	made of/with	l	m ³ /h*1	l/min*1	bar	bar

"Midi" filter regulator			manual drain, relieving, max. 17 bar without pressure gauge, 40 μ m filter element					B11		
60	210	120	metal / sight glass	0.12	120	2000	17	G $\frac{1}{4}$	0.2 ... 1.8	B11-02WJA
									0.2 ... 4.0	B11-02WJB
									0.3 ... 9.0	B11-02WJC
									0.5 ... 17	B11-02WJD
60	210	120	metal / sight glass	0.12	132	2200	17	G $\frac{3}{8}$	0.2 ... 1.8	B11-03WJA
									0.2 ... 4.0	B11-03WJB
									0.3 ... 9.0	B11-03WJC
									0.5 ... 17	B11-03WJD
60	210	120	metal / sight glass	0.12	138	2300	17	G $\frac{1}{2}$	0.2 ... 1.8	B11-04WJA
									0.2 ... 4.0	B11-04WJB
									0.3 ... 9.0	B11-04WJC
									0.5 ... 17	B11-04WJD



Special options, add the appropriate letter

T-handle	locknut included, height = 215 mm	B12-0
5 μm filter element		B11-0 . . . G.
bowl w/o sight glass	max. 21 bar, 0 °C to 80 °C / 32 °F to 176 °F for appropriately conditioned compressed air down to -30 °C / -22 °F	B12-0 . D . .
NPT	connection thread	B11-0 N
non-relieving	without relieving function	B11-0 K
semiautomatic drain	RK500SY, max. 12 bar	B11-0 M
automatic drain	SA605MD, max. 12 bar	B11-0 R
FKM elastomer	inner parts made of brass	B11-0 X64

Accessories, enclosed

pressure gauge	Ø 50 mm, 0 ... *2 bar, G $\frac{1}{4}$	MA5002- . . *2
mounting bracket	made of steel	BW45-02
mounting nut	made of plastic	M45x1,5K
	made of aluminium	M45x1,5A

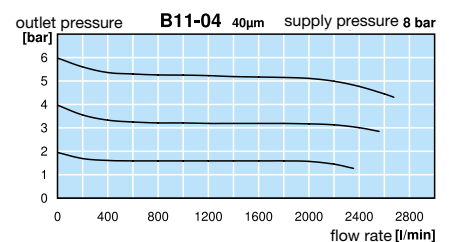
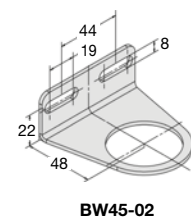
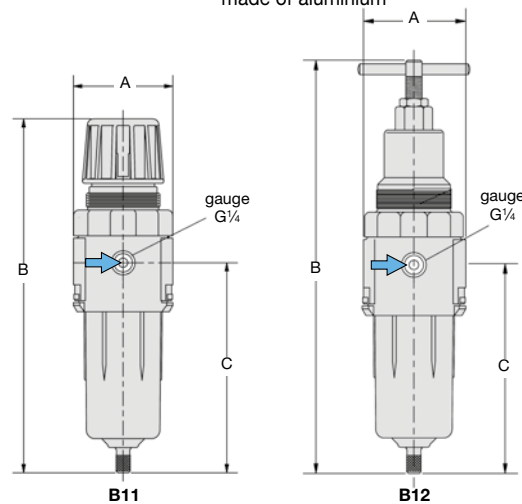

*1 at 8 bar supply pressure, 6 bar outlet pressure and 1 bar pressure drop
*2 02 = 0...2.5 bar, 04 = 0...4 bar, 10 = 0...10 bar, 25 = 0...25 bar

Extensions: see chapter for FRL service units
Gauges: see chapter for measuring devices
Spare parts: see separate spare parts list

PDF CAD
www.aircom.net

Order example:
B11-02WJA

FILTER PRESSURE REGULATOR MADE OF PLASTIC

B042... B095

Description	Modular pressure filter regulator which can be interlocked with all other instruments of the same series.		
Media	compressed air or non-corrosive gases		
Supply pressure	max. 12,5 bar, max. 16 bar for Series 042		
Adjustment	by knob with snap-lock		
Relieving function	relieving		
Gauge port	G $\frac{1}{8}$ or G $\frac{1}{4}$ at series 095, on both sides of the body, screw plugs supplied		
Filter element	20 μ m, optionally 5 μ m, made of sintered polyethylene		
Bowl	plastic version with bayonet catch, threaded connection at series 042		
Drainage	manual drain with semiautomatic drain, optionally automatic drain		
Temperature range	0 °C to 50 °C / 32 °F to 122 °F		
Material	Body: nylon, POM at series 042	Inner valve: brass	
	Bowl: polyamide	Thread insert: brass	
	Elastomer: NBR/Buna-N		

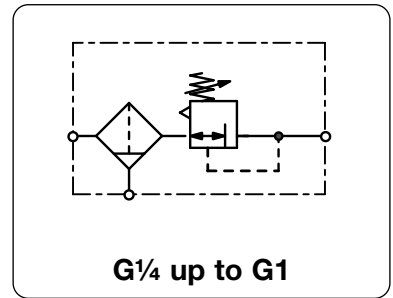

Dimensions			Bowl		Flow rate	Supply max.	Connection thread	Order number
A	B	C	Design	Capacity				
mm	mm	mm	made of/with	l	m 3 /h*1	l/min*1	bar	G

Plastic filter regulator					manual drain with semiautomatic drain, relieving, max. 12,5/16 bar w/o gauge, pressure range 0...8 bar, 20 μ m filter element			B0	
42	207	126	plastic/	0.02	72	1200	16	G $\frac{1}{4}$	B042-02HC
52	239	148	bowl guard	0.04	120	2000	12.5	G $\frac{3}{8}$	B050-03HC
52	239	148		0.04	126	2100	12.5	G $\frac{1}{2}$	B052-04HC
63	276	173		0.10	168	2800	12.5	G $\frac{1}{2}$	B075-04HC
137	276	173		0.10	174	2900	12.5	G $\frac{3}{4}$	B080-06HC
195	411	237		0.20	828	13800	12.5	G1	B095-08HC



Special options, add the appropriate letter

5 μm filter element		for B042 to B080	B0..-0.G.
		for B095	B095-0.G.
non-relieving	without relieving function	for all	B0..-0...K
0... 4 bar pressure range		for B042 to B080	B0..-0..B
		for B095	B095-0..B
0...12 bar pressure range		for B042 to B080	B0..-0..D
		for B095	B095-0..D
automatic drain			B0..-0...R

Accessories, enclosed

pressure gauge	\varnothing 40 mm, 0...*2 bar, G $\frac{1}{8}$	for B042	MA4001-...*
	\varnothing 50 mm, 0...*2 bar, G $\frac{1}{8}$	for B050 to B080	MA5001-...*
	\varnothing 63 mm, 0...*2 bar, G $\frac{1}{4}$	for B095	MA6302-...*
mounting bracket	made of steel, mounting nut at the device	for B042	BW30-01
		for B050 to B080	BW42-01
		for B095	BW00-02

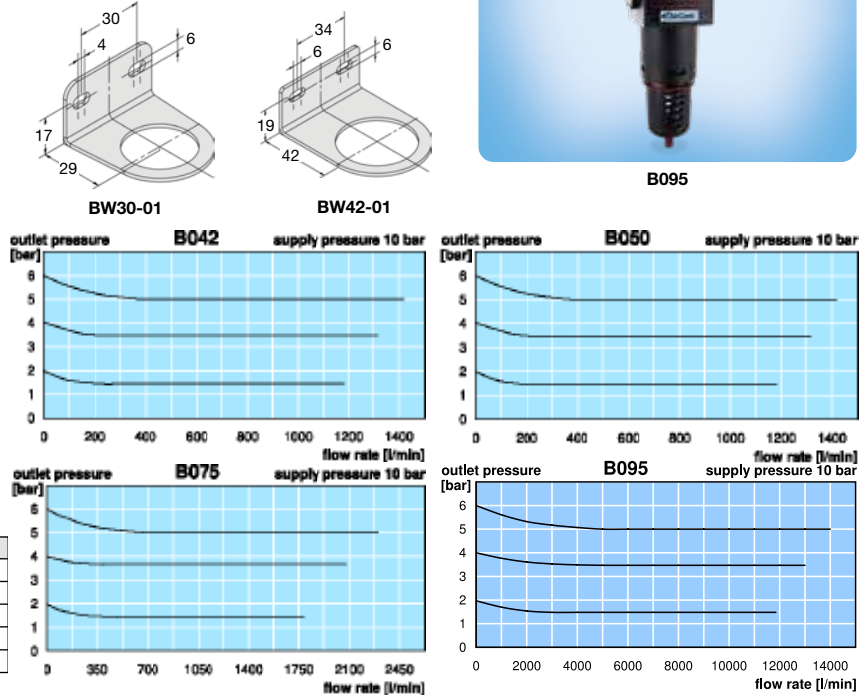
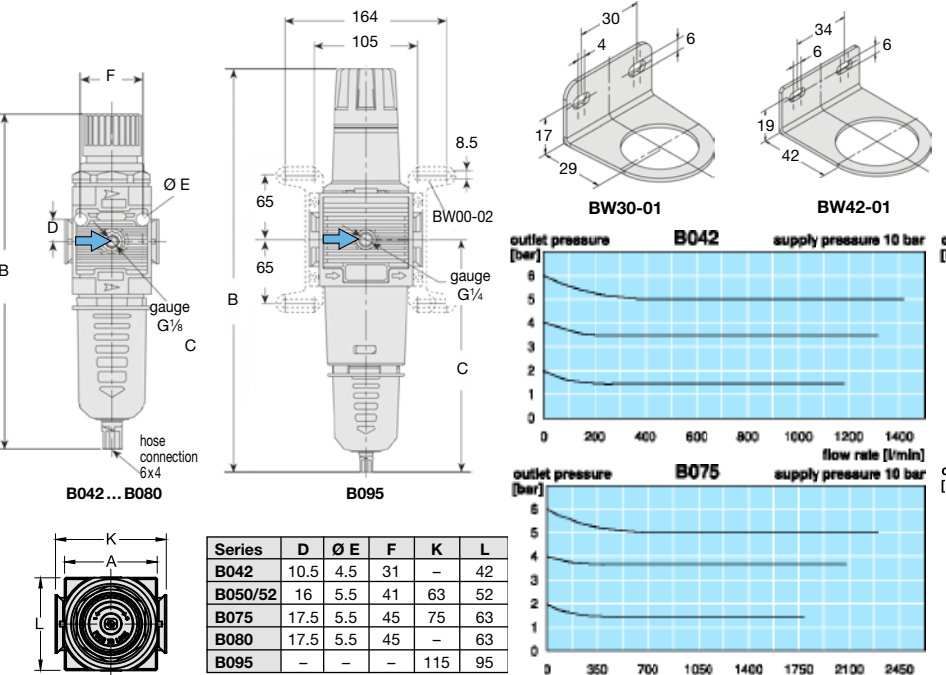

*1 at 10 bar supply pressure, 6 bar outlet pressure and 1 bar pressure drop *2 04 = 0...4 bar, 10 = 0...10 bar, 16 = 0...16 bar

Extensions: see chapter for FRL service units
 Gauges: see chapter for measuring devices
 Spare parts: see separate spare parts list

PDF CAD
www.aircom.net

Order example:
B042-02HC

"MAXI" FILTER PRESSURE REGULATOR

B20 / B21

Description	High-capacity filter regulator of modular design with exchangeable inserts. Can be interlocked with lubricator without needs for double nipples. Each "maxi" device may be taken from a fixed line in seconds by simply removing the mounting bolts.		
Media	compressed air or non-corrosive gases		
Supply pressure	max. 17 bar		
Adjustment	by plastic knob with snap-lock at B20, by T-handle with locknut at B21		
Relieving function	relieving	Gauge port	G $\frac{1}{4}$ on both sides of the body, screw plugs supplied
Bowl	metal version with sight glass		
Drainage	manual drain as standard, optionally semiautomatic or automatic drain for max. 12 bar	Filter element	40 μ m, optionally 5 μ m, made of polypropylene
Temperature range	0 °C to 70 °C / 32 °F to 158 °F up to 50 °C / 122 °F for semiautomatic or automatic drain version		
Material	Body: zinc die-cast Knob (B20): glass fibre-reinforced plastic Bowl: zinc die-cast Elastomer: NBR/Buna-N	Spring cage: zinc die-cast T-handle (B21): steel Sight glass: polyurethane Inner valve: brass and plastic	

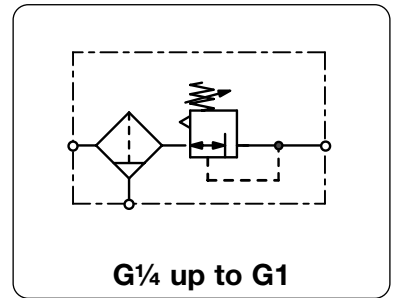

Dimensions			Bowl	Flow	Connection	Pressure	Order
A	B	C	Design	Capacity	rate	range	number
mm	mm	mm	made of / with	l	m 3 /h*1	bar	

"Maxi" filter regulator								with manual drain, relieving, without gauge, 40 μ m filter element, max. 17 bar	B20			
89	289	175	metal/sight glass	0.3	132	2200	G $\frac{1}{4}$	0.2... 4.0	B20-02WJB			
								0.3... 9.0	B20-02WJC			
								0.5... 17	B20-02WJD			
								186	3100	G $\frac{3}{8}$	0.2... 4.0	B20-03WJB
											0.3... 9.0	B20-03WJC
											0.5... 17	B20-03WJD
111	289	175	metal/sight glass	0.3	408	6800	G $\frac{1}{2}$	0.2... 4.0	B20-04WJB			
								0.3... 9.0	B20-04WJC			
								0.5... 17	B20-04WJD			
								420	7000	G1	0.2... 4.0	B20-06WJB
											0.3... 9.0	B20-06WJC
											0.5... 17	B20-06WJD
							0.2... 4.0	B20-08WJB				
							0.3... 9.0	B20-08WJC				
							0.5... 17	B20-08WJD				



Special options, add the appropriate letter

T-handle	including locknut, total height 329 mm	B21-0 . W . .
filter element 5 μm		B20-0 . WG.
NPT	connection thread	B20-0 . W . .N
non-relieving	without relieving function	B20-0K
semiautomatic drain	RK500SY, max. 12 bar	B20-0 . W . .M
automatic drain	SA605MD, max. 12 bar	B20-0 . W . .R



Accessories, enclosed

pressure gauge	\varnothing 63 mm, 0...*2 bar, G $\frac{1}{4}$	MA6302-..*2
mounting bracket	mounting at the spring cage	BW45-02
mounting nut	made of plastic	M45x1,5K
	made of aluminium	M45x1,5A
mounting bracket set	made of steel	MK20-0100

Filter
regulator

17

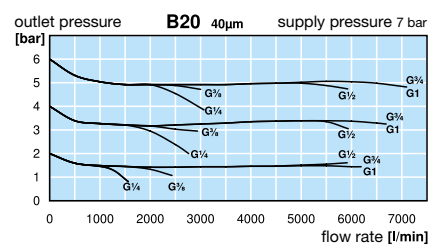
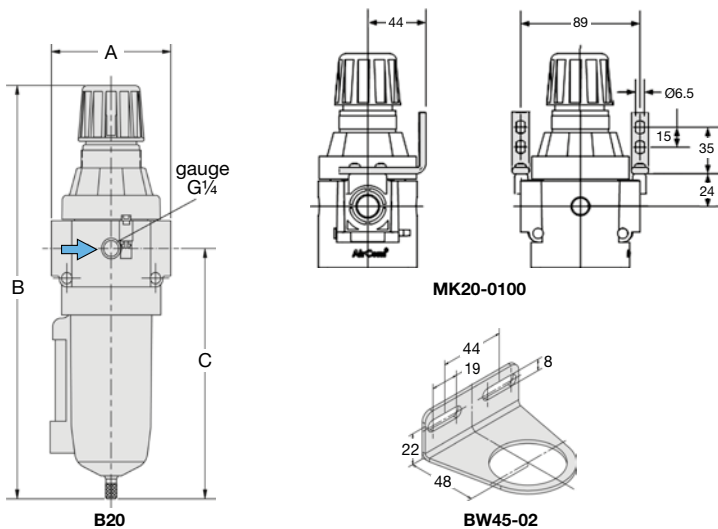

*1 at 7 bar supply pressure, 6 bar outlet pressure and 1 bar pressure drop *2 04 = 0...4 bar, 10 = 0...10 bar, 25 = 0...25 bar

Extensions: see chapter for FRL service units
Gauges: see chapter for measuring devices
Spare parts: see separate spare parts list

PDF CAD
www.aircom.net

Order example:
B20-02WJB

FILTER PRESSURE REGULATOR SERIES "D", UP TO 30 BAR

BD

Description Low-cost zinc die-cast regulator of solid design and diaphragm operating system up to G $\frac{1}{2}$. From G $\frac{3}{4}$ on with piston operating system. Suitable for compressed air or non-corrosive gases.

Supply pressure max. 16 bar for metal bowl with sight glass

Adjustment by knob with snap-lock up to G $\frac{1}{2}$, by hexagon head screw from G $\frac{3}{4}$ up to G1 $\frac{1}{2}$ (BD-1A), by T-handle from G1 $\frac{1}{2}$ (BD-12.) up to G2

Gauge port G $\frac{1}{4}$ on both sides of the body, G $\frac{1}{8}$ on both sides of the body at BD-01/02, one screw plug supplied

Filter element 50 μ m, optionally 5 μ m, made of propylene

Bowl plastic version, standard or short, metal version with or without sight glass

Drainage semiautomatic drain as standard for max. 16 bar, respectively manual drain max. 30 bar, automatic drain max. 16 bar as option

Temperature range -10 °C to 50 °C / 14 °F to 122 °F for metal bowl with sight glass, for G $\frac{1}{8}$ up to G $\frac{1}{2}$
-20 °C to 80 °C / -4 °F to 140 °F for metal bowl with sight glass, for G $\frac{3}{4}$ up to G2
-30 °C to 80 °C / -22 °F to 176 °F for metal bowl without sight glass, for all sizes

Material
Body: zinc die-cast at G $\frac{1}{8}$ and G $\frac{1}{4}$, aluminium at G $\frac{3}{8}$ to G2
Elastomer: NBR/Buna-N
Bowl: zinc die-cast

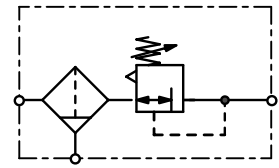

G $\frac{1}{8}$ up to G2
5/50 μ m, up to 30 bar

Dimensions			Bowl	Flow	P ₁	Filter	Connection	Order
A	B	C	Design	rate	max.	element	thread	number
mm	mm	mm	made of/with	l m ³ /h*1	l/min*1	μ m	G	

Filter pressure regulator										
with semiautomatic drain, relieving, without pressure gauge, pressure range 0.5...8 bar										
									BD	
40	201	128	metal/sight glass	0.05	27	450	16	50	G $\frac{1}{8}$	BD-01M BD-01NH
			metal	0.05			30			
40	201	128	metal/sight glass	0.05	30	500	16	50	G $\frac{1}{4}$	BD-02M BD-02NH
			metal	0.05			30			
64	248	148	metal/sight glass	0.18	108	1800	16	50	G $\frac{3}{8}$	BD-03M BD-03NH
			metal	0.18			30			
64	248	148	metal/sight glass	0.18			16		G $\frac{1}{2}$	BD-04M BD-04NH
			metal	0.18			30			
130	314	179	metal/sight glass	0.50	300	5000	16	50	G $\frac{3}{4}$	BD-06M BD-06NH
			metal	0.50			30			
130	314	179	metal/sight glass	0.50			16		G1	BD-08M BD-08NH
			metal	0.50			30			
241	314	179	metal/sight glass	0.50	390	6500	16	50	G1 $\frac{1}{4}$	BD-10M BD-10NH
			metal	0.50			30			
241	314	179	metal/sight glass	0.50			16		G1 $\frac{1}{2}$	BD-1AM BD-1ANH
			metal	0.50			30			



BD-01/-02M



BD-03/-04M



BD-10NH

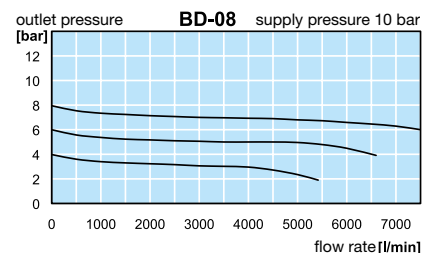
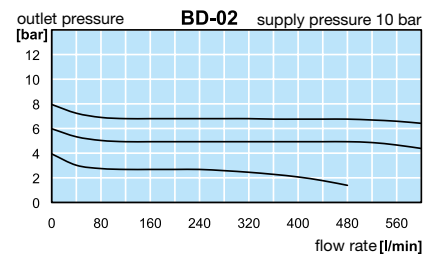

Type	M	D	Ø E
BD-01/02	M30x1,5	30	4.5
BD-03/04	M50x1,5	51	5.5

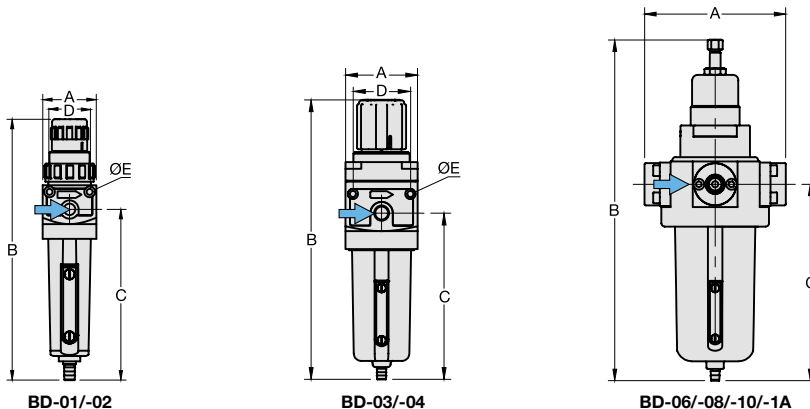

*1 at 8 bar supply pressure, 6 bar outlet pressure and 1 bar pressure drop

*2 04 = 0...4 bar, 10 = 0...10 bar, 16 = 0...16 bar

Extensions: see chapter for FRL service units
Gauges: see chapter for measuring devices
Spare parts: see separate spare parts list

PDF CAD
www.aircom.net

Order example:
BD-01M



FILTER PRESSURE REGULATOR SERIES "D", UP TO 30 BAR

BD

Description	Low-cost zinc die-cast regulator of solid design and diaphragm operating system up to G $\frac{1}{2}$. From G $\frac{3}{4}$ on with piston operating system. Suitable for compressed air or non-corrosive gases.
Supply pressure	max. 16 bar for metal bowl with sight glass
Adjustment	by knob with snap-lock up to G $\frac{1}{2}$, by hexagon head screw from G $\frac{3}{4}$ up to G1 $\frac{1}{2}$ (BD-1A), by T-handle from G1 $\frac{1}{2}$ (BD-12.) up to G2
Gauge port	G $\frac{1}{4}$ on both sides of the body, G $\frac{1}{8}$ on both sides of the body at BD-01/02, one screw plug supplied
Filter element	50 μ m, optionally 5 μ m, made of propylene
Bowl	plastic version, standard or short, metal version with or without sight glass
Drainage	semiautomatic drain as standard for max. 16 bar, respectively manual drain max. 30 bar, automatic drain max. 16 bar as option
Temperature range	-10 °C to 50 °C / 14 °F to 122 °F for metal bowl with sight glass, for G $\frac{1}{8}$ up to G $\frac{1}{2}$ -20 °C to 60 °C / -4 °F to 140 °F for metal bowl with sight glass, for G $\frac{3}{4}$ up to G2 -30 °C to 80 °C / -22 °F to 176 °F for metal bowl without sight glass, for all sizes
Material	Body: zinc die-cast at G $\frac{1}{8}$ and G $\frac{1}{4}$, aluminium at G $\frac{3}{8}$ to G2 Elastomer: NBR/Buna-N Bowl: zinc die-cast

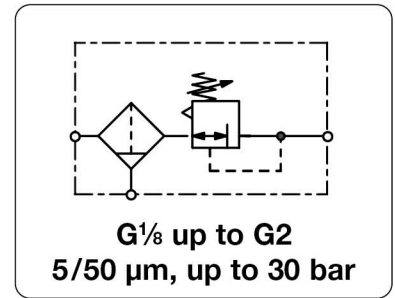

Dimensions			Bowl	Flow	P ₁	Filter	Connection	Order
A	B	C	Design	Capacity	rate	element	thread	number
mm	mm	mm	made of/ with	l	m ³ /h*1 l/min*1	μ m	G	

Filter pressure regulator									with semiautomatic drain, relieving, without pressure gauge, pressure range 0.5...8 bar	BD
192	429	220	metal/sight glass	1.20	960	16 000	16	G1 $\frac{1}{2}$		BD-12M
			metal	1.20			30			BD-12NH
192	429	220	metal/sight glass	1.20	1020	17 000	16	G2		BD-16M
			metal	1.20			30			BD-16NH



BD-12/-16

Special options, add the appropriate letter

5 μ m filter element		for G $\frac{1}{8}$ to G $\frac{1}{2}$	BD-... G
		for G $\frac{3}{4}$ to G1	BD-... G
		for G1 $\frac{1}{4}$ to G2	BD-... G
0.3 ... 3 bar regulating range			BD-... B
1 ... 15 bar regulating range			BD-... E
manual drain	max. 16 bar for metal bowls with sight glass		BD-... H
automatic drain	max. 16 bar, drainage through float valve	for G $\frac{3}{8}$ to G2	BD-... R
flange connection	see chapter for stainless steel devices / flanges		BD-... F.

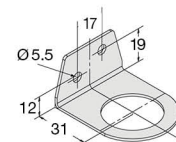

BW30-02

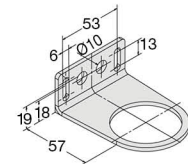

BW50-03

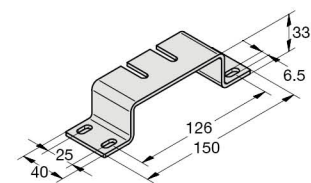

BW00-59S

Accessories, enclosed

pressure gauge	\varnothing 40 mm, 0... ^{*2} bar, G $\frac{1}{8}$ \varnothing 50 mm, 0... ^{*2} bar, G $\frac{1}{4}$ \varnothing 63 mm, 0... ^{*2} bar, G $\frac{1}{4}$	for G $\frac{1}{8}$ and G $\frac{1}{4}$ for G $\frac{3}{8}$ and G $\frac{1}{2}$ for G $\frac{3}{4}$ up to G2	MA4001-... ^{*2} MA5002-... ^{*2} MA6302-... ^{*2}
mounting bracket	made of steel	for G $\frac{1}{8}$ and G $\frac{1}{4}$	BW30-02
mounting nut	made of plastic	for G $\frac{1}{8}$ and G $\frac{1}{4}$	M30x1,5K
mounting bracket	made of steel	for G $\frac{3}{8}$ and G $\frac{1}{2}$	BW50-03
mounting nut	made of plastic	for G $\frac{3}{8}$ and G $\frac{1}{2}$	M50x1,5K
mounting bracket	made of stainless steel	for G $\frac{3}{4}$ up to G1 $\frac{1}{2}$ (1A)	BW00-59S
set of brackets	made of steel	for G1 $\frac{1}{2}$ (12) and G2	BW00-61

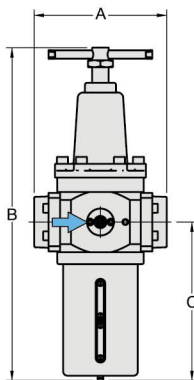

BD-12/-16

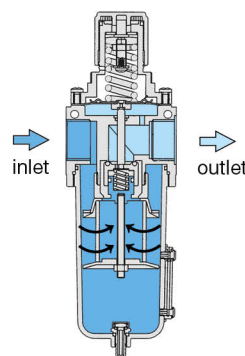

cross-section

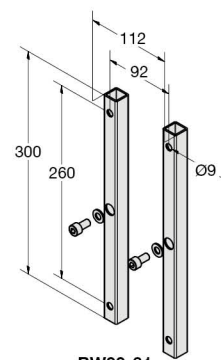

BW00-61

*1 at 8 bar supply pressure, 6 bar outlet pressure and 1 bar pressure drop

*2 04 = 0...4 bar, 10 = 0...10 bar, 16 = 0...16 bar

Extensions: see chapter for FRL service units
Gauges: see chapter for measuring devices
Spare parts: see separate spare parts list

PDF CAD
www.aircom.net



Order example:
BD-12M

Description	Filter pressure regulator especially for low temperatures as well as supply of instruments.
Media	compressed air or non-corrosive gases
Supply pressure	max. 17 bar
Supply sensitivity	10 mbar outlet pressure deviation at supply pressure variation of 1 bar
Air consumption	max 2 l/min subject to outlet pressure
Adjustment	by square-headed spindle (spanner size 8 mm) with locknut
Relieving function	relieving, optionally non-relieving
Gauge port	1/4" NPT on one side of the body, one screw plug supplied
Filter element	40 µm, optionally 5 µm, made of impregnated cellulose
Drainage	manual drain
Temperature range	0 °C to 50 °C / 32 °F to 122 °F, for appropriately conditioned compressed air down to -40 °C / -40 °F
Material	Body: aluminium die-cast Spring cage: aluminium die-cast Elastomer: nylon-reinforced NBR/Buna-N, optionally FKM Inner valve: brass, acetal, galvanised steel

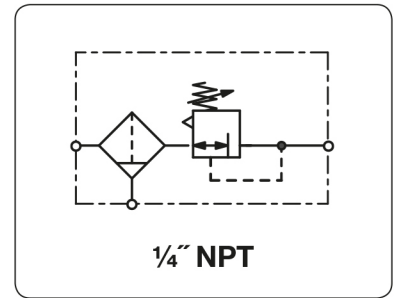

Dimensions			Bowl	Flow	P ₁	Connection	Pressure	Order
A	B	C	Design	Capacity	rate	max. thread	range	number
mm	mm	mm	made of	l	m ³ /h*1	l/min*1	bar	

Filter pressure regulator								with manual drain, relieving, without gauge, 40 µm filter element	B300	
197	80	83	metal	0.1	33	550	17	1/4" NPT	0...0.7	B300-020
									0...2.0	B300-02A
									0...4.0	B300-02B
									0...8.0	B300-02C



B300

Special options, add the appropriate letter

5 µm filter element		B300-02 . G
non-relieving	without relieving function	B300-02 . K
tapped exhaust	1/4" NPT	B300-02 . X12
tamper-proof cap		B300-02 . T
FKM-elastomer		B300-02 . V

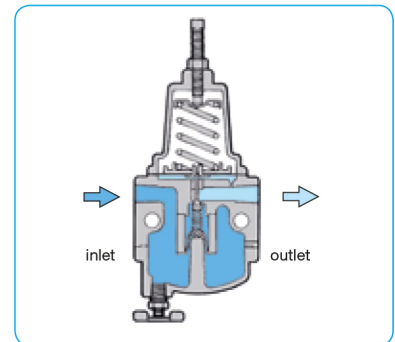

Accessories, enclosed

mounting bracket	mounting at spring cage, made of steel	BW00-38
-------------------------	--	----------------

Filter regulator

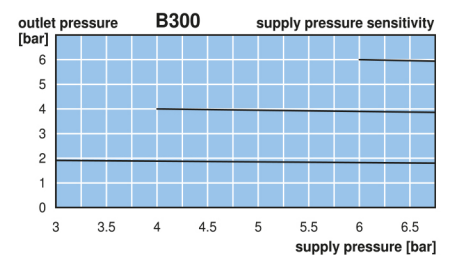
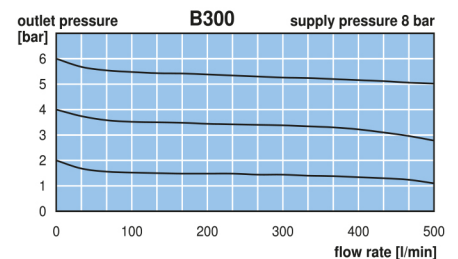
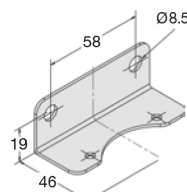
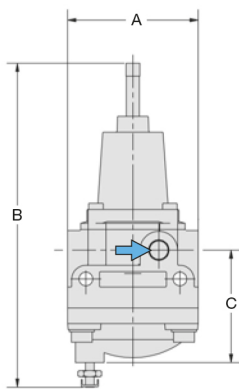

*1 at 8 bar supply pressure, 6 bar outlet pressure and 1 bar pressure drop

Extensions: see chapter for FRL service units
Spare parts: see separate spare parts list

PDF CAD
www.aircom.net



Order example:
B300-020